

RSACH Series

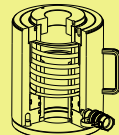

Capacity:
20-100 ton

Stroke:
50-250 mm

Maximum Operating Pressure:
700 bar

RSACH 液壓單動中空，鋁合金千斤頂

- 鋁合金設計，質輕易攜帶。
- 7075-T6鋁合金材質，能以最小重量承最大能力。
- 墊塊及缸底墊塊預防荷重的危險。
- 主軸及缸壁內外陽極處理防損耐腐且延長使用壽命。
- 強力彈簧加速主軸回縮速度。
- 特殊軟質環設計，防止主軸偏心荷載；避免磨耗刮傷油缸。
- 多層油封設計，預防金屬材質間互相磨擦，防止側向荷載受損。
- 上螺帽保護主軸超揚昇。
- 各型號均含SQB-3/8UF快速接頭及防塵蓋。

Single-Acting, Hollow Plunger Aluminum Cylinders

- ※ Lightweight, aluminum design for maximum portability.
- ※ 7075-T6 Aluminum alloy components for maximum strength and minimum weight.
- ※ Steel baseplate and saddle for protection against piston rod damage.
- ※ Anodizing treatment plunger, surfaces and inner of barrel resists damage and extends cylinder life.
- ※ Maximum sized springs speed piston return and increase spring life.
- ※ Special soft ring reduces wear caused by off-center loads.
- ※ Composite bearings prevent metal-to-metal contact, increasing cylinder life and resistance to side-load.
- ※ Stop ring for piston blow-out protection.
- ※ All cylinders are equipped with SQB-3/8UF female coupler & dust cap.

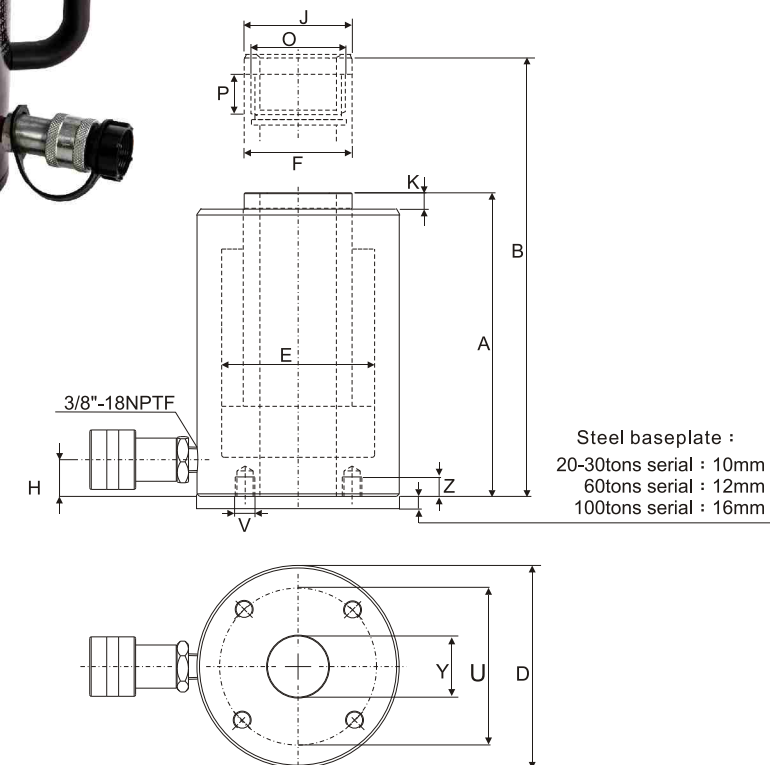

缸底墊塊底座螺孔 Steel Base Plate Mounting Holes

Cylinder Model/ Capacity	Bolt Circle U (mm)	Thread V (mm)	Thread Depth Z (mm)
RSACH-20	80.0	M6	12
RSACH-30	110.0	M6	12
RSACH-60	160.0	M6	12
RSACH-100	230.0	M6	12

*含缸底墊塊高6mm *Including Base Plate Height of 6mm.
*4缸底墊塊螺孔:M6x1.0x0.24 *4 base plate bolts:M6X1.0X0.24

This drawing show the base mounting holes of barrel before setting steel base plate.

墊塊/鞍座 Saddle

RSACH-系列 均配有高硬度可移除式溝槽墊塊於起重時具防滑作用。偏心起重時請選用傾斜墊塊。

RSACH-Series are equipped with hardened removable "Ribbed saddles" to prevent slippage during jacking. For off-centre loading application, see optional tilting saddle.

缸底墊塊 Steel Base Plate

- 缸底墊塊作用於保護油壓缸底座免於損壞；不可任意移除。
- 千萬不要使用這些螺孔來安裝其他配件或設備在油壓缸上。

※ Do not remove steel base plate in order to protect the cylinder base.
※ No attachment to be used on base holes of the Aluminum cylinders.

鋁 VS. 鋼性質說明

Aluminum vs. Steel characteristic

- 鋁和鋼材的不同，在於鋁具較低的金屬疲乏。意即鋁合金油壓缸不適用於高重複性使用。

※ Due to different steel & Aluminum characteristics, it is strongly recommended not to be used for high-cycle applications

Handle type	Model Number
提把型式	型號
(S)	
■	RSACH-202
■	RSACH-206
■	RSACH-302
■	RSACH-306
■	RSACH-3010
■	RSACH-604
■	RSACH-606
■	RSACH-1003
■	RSACH-1006

提把型式 Handle type
(S) : 標準配件 standard equipped
(O) : 選配 option
● 焊提把 Weldable
★ 吊環螺柱 Eyebolt
▲ 活動提把 Removable strap handles
■ 螺牙式活動提把 Thread

Outer Dimension 外部尺寸														
Cyl. Cap.	Stroke	Cyl. Effective Area	Oil Cap.	Coll. Ht.	Ext. Ht.	Out. Diam.	Cyl. Bore Diam.	Plngr. Diam.	Base to Advance Port	Saddle Diam.	Saddle Protr. from Plngr.	Center Hole Diam.	Wt.	
能力 ton(kN)	揚程 (mm)	受壓面積 (cm ²)	使用油量 (cm ³)	本身高 A (mm)	伸長總高 B (mm)	外徑 D (mm)	內徑 E (mm)	主軸直徑 F (mm)	底部前進油孔位置 H (mm)	墊塊直徑 J (mm)	凸出高度 K (mm)	中孔直徑 Y (mm)	總重 (Kg)	
20 (229)	50.0	32.7	163.7	188	238	100	75	55	29.0	55	10.0	27	5.2	
	150.0	32.7	491.0	315	465	100	75	55	29.0	55	10.0	27	7.1	
30 (358)	50.0	51.1	255.7	208	258	130	95	70	29.0	70	10.0	34	8.0	
	150.0	51.1	767.0	333	483	130	95	70	29.0	70	10.0	34	11.2	
	254.0	51.1	1298.9	457	711	130	95	70	29.0	70	10.0	34	13.7	
60 (596)	100.0	84.7	847.7	315	415	180	130	100	61.2	100	12.0	54	19.5	
	150.0	84.7	1271.5	380	530	180	130	100	61.2	100	12.0	54	22.8	
100 (1157)	76.0	178.9	1360.0	307	383	250	182	145	51.0	145	14.0	79	44.0	
	150.0	178.9	2684.0	391	541	250	182	145	51.0	145	14.0	79	54.5	